

LEGENDA COLORI/COLOUR KEY  
 Ar ARANCIO/ORANGE  
 Az AZZURRO/AZURE  
 Bi BIANCO/WHITE  
 Bl BLU/BLUE  
 Gg GIALLO/YELLOW  
 Gr GRIGIO/GRAY  
 Ma MARRONE/BROWN  
 Ne NERO/BLACK  
 Rr ROSA/PINK  
 Rr ROSSO/RED  
 Vg VERDE/GREEN  
 Vi VIOLA/VIOLET

1	CONNETTORI MULTIPLI/MULTIPLE CONNECTORS	13	COMMUTATORE LAMPEGGIATORI/TURN INDICATOR SWITCH	25	BOBINA ACCENSIONE/IGNITION COIL	37	FANALE ANT./TURN INDICATOR LH
2	CLAXON/HORN	14	PULSANTE AVVIAMENTO/STARTER BUTTON	26	CANDELA/SPARK PLUG	38	SPIA RISERVA CARBURANTE/LOW FUEL WARNING LIGHT
3	PULSANTE CLAXON/HORN SWITCH	15	INTERRUTTORE STOP ANT./FRONT STOP SWITCH	27	PICK UP/PICK-UP	39	MASSA TELAIO/CHASSIS GROUND
4	SPIA LIVELLO OLIO/OIL LEVEL WARNING LIGHT	16	INTERRUTTORE STOP POST./REAR STOP SWITCH	28	GENERATORE/ALTERNATOR	40	CABL'AGGIO TARGA -CH-/LICENSE PLATE CABLE HARNESS -CH-
5	LAMPADINE ILLUMINAZIONE CRUSCOTTO/ INSTRUMENT PANEL LIGHTING BULBS	17	INDICATORE DIREZ. POST. SX/REAR STOP SWITCH	29	REGOLATORE/REGULATOR	41	DISPOSITIVO COMANDO RISCALDATORE/ HEATER COMMAND DEVICE
6	SPIA LUCE ABBAGLIANTE/HIGH-BEAM WARNING LIGHT	18	FANALE POST./TAILLIGHT	30	STARTER AUTOMATICO/AUTOMATIC STARTER	42	RISCALDATORE/HEATER
7	SPIA INDICATORE DIREZIONE/TURN INDICATOR WARNING LIGHT	19	LUCE TARGA/LICENSE PLATE LAMP	31	INDICATORE RISERVA OLIO/OIL RESERVE INDICATOR		
8	STRUMENTO LIVELLO CARBURANTE/FUEL LEVEL INSTRUMENT	20	INDICATORE DIREZ. POST. DX/LICENSE PLATE LAMP	32	INDICATORE DIREZ. ANT. DX/OIL RESERVE INDICATOR		
9	CRUSCOTTO/INSTRUMENT PANEL	21	RELE' AVVIAMENTO/STARTER RELAY	33	LUCE ABBAGLIANTE/HIGH-BEAM LIGHT		
10	TRASMETTITORE LIVELLO CARBURANTE/FUEL LEVEL TRANSMITTER	22	MOTORINO AVVIAMENTO/STARTER MOTOR	34	LUCE POSIZIONE/DAYLIGHT RUNNING LIGHT		
11	DEVIATORE LUCI/LIGHT SWITCH	23	BATTERIA/BATTERY	35	LUCE ANABBAGLIANTE/LOW BEAM LIGHT		
12	INTERRUTTORE CHIAVE/KEY SWITCH	24	FUSIBILE PRINCIPALE/MAIN FUSE	36	INDICATORE DIREZ. ANT. SX/TURN INDICATOR LH		



Typhoon 50 "2T"



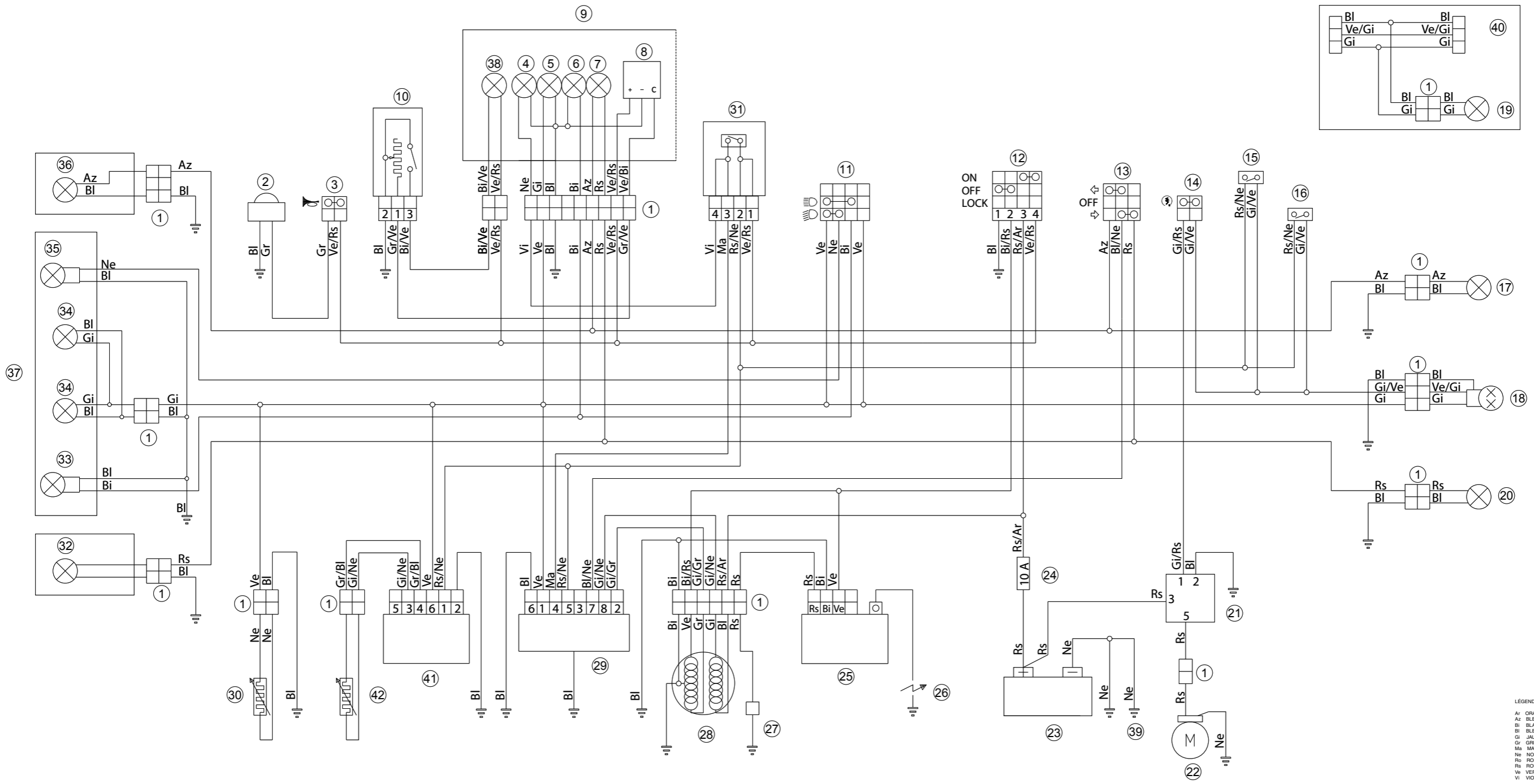

LÉGENDE COULEURS/ZEICHENERKLÄRUNG FARBEN

- A: ORANGE/ORANGE
- Az: BLEU CLAIR/HELLBLAU
- Bl: BLANC/WEISS
- Bl: BLEU/BLAU
- Gi: JAUNE/GELB
- Gr: GRIS/GRAU
- Ma: MARRON/BRAUN
- Ne: NOIR/SCHWARZ
- Rs: ROSE/ROSA
- Rs: ROUGE/ROT
- Ve: VERT/GRÜN
- Vi: VIOLET/VIOLETT

1	CONNECTEURS MULTIPLES/MEHRFACHSTECKER	13	COMMUTATEUR DES CLIGNOTANTS/ BLINKERSCHALTER	25	BOBINE D'ALLUMAGE/ZÜNDSPULE	37	FEU AV./LICHT VORNE
2	KLAXON/HUPE	14	BOUTON DE DÉMARRAGE/ANLASSERSCHALTER	26	BOUGIE/ZÜNDKERZE	38	VOYANT RÉSERVE CARBURANT/ BENZINRESERVEKONTROLLE
3	BOUTON DU KLAXON/HUPENSCHALTER	15	INTERRUPTEUR STOP AV./SCHALTER VORD. BREMSLICHT	27	PICK-UP/PICK-UP	39	MASSE CADRE/ MASSE RAHMEN
4	VOYANT DE NIVEAU D'HUILE/ KONTROLLLAMPE ÖLSTAND	16	INTERRUPTEUR STOP ARR./SCHALTER HINT. BREMSLICHT	28	GÉNÉRATEUR/LICHTMASCHINE	40	CÂBLAGE DE LA PLAQUE D'IMMATRICULATION -CH/ KABELBAUM KENNZEICHEN -CH-
5	AMPOULES D'ÉCLAIRAGE DU TABLEAU DE BORD/ LAMPEN ARMATURENBRETTBELEUCHTUNG	17	CLIGNOTANT ARR. G./BLINKER HINTEN LINKS	29	RÉGULATEUR/SPANNUNGSREGLER	41	DISPOSITIF DE COMMANDE DU RÉCHAUFFEUR/ STEUERVORRICHTUNG HEIZUNG
6	VOYANT FEU DE ROUTE/FEHNLICHTKONTROLLE	18	FEU ARR./RÜCKLICHT	30	STARTER AUTOMATIQUE/AUTOMATISCHER CHOKE	42	RÉCHAUFFEUR/ HEIZUNG
7	VOYANT DU CLIGNOTANT/ KONTROLLLAMPE BLINKER	19	FEU PLAQUE D'IMMATRICULATION/ NUMMERSCHILDBELEUCHTUNG	31	INDICATEUR DE RÉSERVE D'HUILE/ ANZEIGER ÖLRESERVE		
8	INSTRUMENT NIVEAU DE CARBURANT/ INSTRUMENT BENZINSTAND	20	CLIGNOTANT ARR. GAUCHE/BLINKER HINTEN LINKS	32	CLIGNOTANT AV. D./BLINKER VORNE RECHTS		
9	TABLEAU DE BORD/ARMATURENBRETT	21	RELAIS DE DÉMARRAGE/ANLASSERRELAIS	33	FEU DE ROUTE/ FEHNLICHT		
10	ÉMETTEUR DU NIVEAU DE CARBURANT/ BENZINSTANDGEBER	22	DÉMARREUR/ANLASSERMOTOR	34	FEU DE POSITION/STANDLICHT		
11	INVERSEUR FEUX/LICHT-WECHSELSCHALTER	23	BATTERIE/BATTERIE	35	FEU DE CROISEMENT/ABBLENDLICHT		
12	INTERRUPTEUR À CLÉ/SCHLÜSSELSCHALTER	24	FUSIBLE PRINCIPAL/HAUPTSICHERUNG	36	CLIGNOTANT GAUCHE/BLINKER LINKS		



Typhoon 50 "2T"



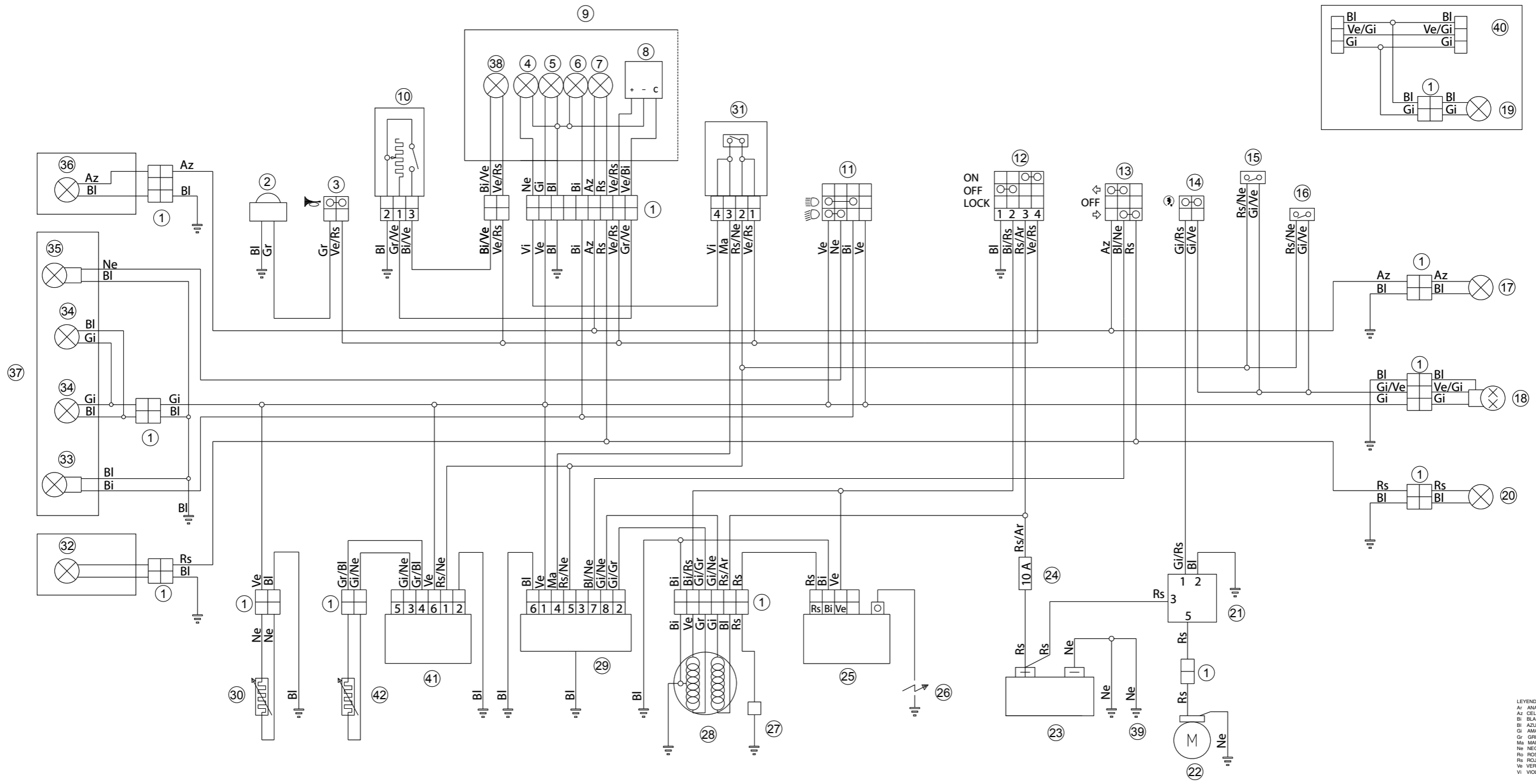

LEYENDA DE COLORES/COLOUR KEY  
 Ar ANARANJADO/YELLOW  
 Az CELESTELIGHT BLUE  
 Bl BLANCO/WHITE  
 Bl AZUL/BLUE  
 Gi AMARILLO/YELLOW  
 Gr GRIS/ GREY  
 Ma MARRÓN/BROWN  
 Ne NEGRO/BLACK  
 Ro ROSA/PINK  
 Rr ROJO/RED  
 Vv VERDE/GREEN  
 Vi VIOLETA/VIOLET

1	CONECTORES MÚLTIPLES/MULTIPLE CONNECTORS	13	CONMUTADOR INTERMITENTES/TURN INDICATOR SWITCH	25	BOBINA DE ENCENDIDO/IGNITION COIL	37	FARO DEL./FRONT HEADLIGHT
2	CLAXON/HORN	14	PULSADOR DE ARRANQUE/STARTER BUTTON	26	BUJÍA/SPARK PLUG	38	TESTIGO DE LA RESERVA DE COMBUSTIBLE/ LOW FUEL WARNING LIGHT
3	PULSADOR CLAXON/HORN SWITCH	15	INTERRUPTOR STOP DEL./FRONT STOP SWITCH	27	PICK-UP/PICK-UP	39	MASA CHASIS/CHASSIS GROUND
4	TESTIGO NIVEL DE ACEITE/OIL LEVEL WARNING LIGHT	16	INTERRUPTOR STOP TRAS./REAR STOP SWITCH	28	ALTERNADOR/ALTERNATOR	40	MAZO DE CABLES MATRICULA -CH-/LICENSE PLATE CABLE HARNESS -CH-
5	BOMBILLAS DE ILUMINACIÓN DEL TABLERO/ INSTRUMENT PANEL LIGHTING BULBS	17	INTERMITENTE TRAS. IZQ./TURN INDICATOR LEFT REAR	29	REGULADOR/REGULATOR	41	DISPOSITIVO DE MANDO CALENTADOR/ HEATER COMMAND DEVICE
6	TESTIGO DE LA LUZ DE CARRETERA/HIGH-BEAM WARNING LIGHT	18	FARO TRAS./TAILLIGHT	30	STARTER AUTOMÁTICO/AUTOMATIC STARTER	42	CALENTADOR/HEATER
7	TESTIGO INTERMITENTE/TURN INDICATOR WARNING LIGHT	19	LUZ DE MATRÍCULA/LICENSE PLATE LAMP	31	INTERMITENTE RESERVA DE ACEITE/ OIL RESERVE INDICATOR		
8	INSTRUMENTO NIVEL DE COMBUSTIBLE/FUEL LEVEL INSTRUMENT	20	INTERMITENTE TRAS. IZQ./TURN INDICATOR REAR LH	32	INTERMITENTE DEL. DER./TURN INDICATOR RIGHT FRONT		
9	TABLERO/INSTRUMENT PANEL	21	RELÉ DE ARRANQUE/STARTER RELAY	33	LUZ DE CARRETERA/HIGH-BEAM LIGHT		
10	TRANSMISOR NIVEL DE COMBUSTIBLE/FUEL LEVEL TRANSMITTER	22	MOTOR DE ARRANQUE/STARTER MOTOR	34	LUZ DE POSICIÓN/DAYLIGHT RUNNING LIGHT		
11	CONMUTADOR DE LUCES/LIGHT SWITCH	23	BATERÍA/BATTERY	35	LUZ DE CRUCE/LOW BEAM LIGHT		
12	INTERRUPTOR DE LLAVE/KEY SWITCH	24	FUSIBLE PRINCIPAL/MAIN FUSE	36	INTERMITENTE IZQ. /TURN INDICATOR LH		